

Instructions for RTS sensor assembly on BMWs with valve on the spoke and threaded hole on the rim

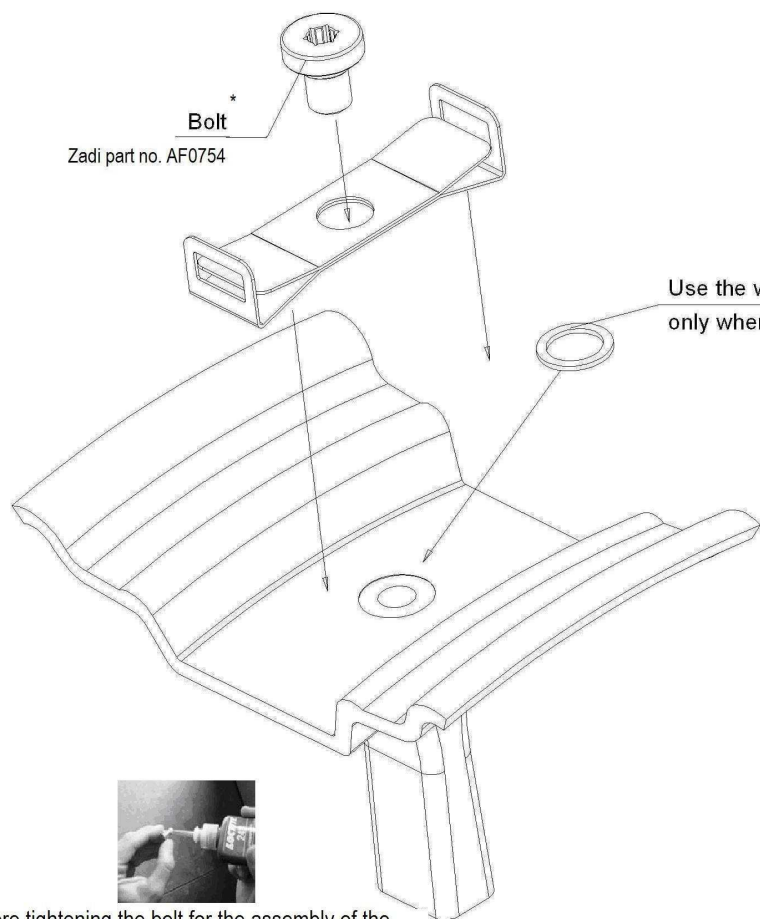

* Before tightening the bolt for the assembly of the support on the rim remember to apply a thread locking compound of mid-high resistance to the threaded surface of the bolt. We suggest "LOCTITE 243" or similar products.

The sensor support must touch the rim

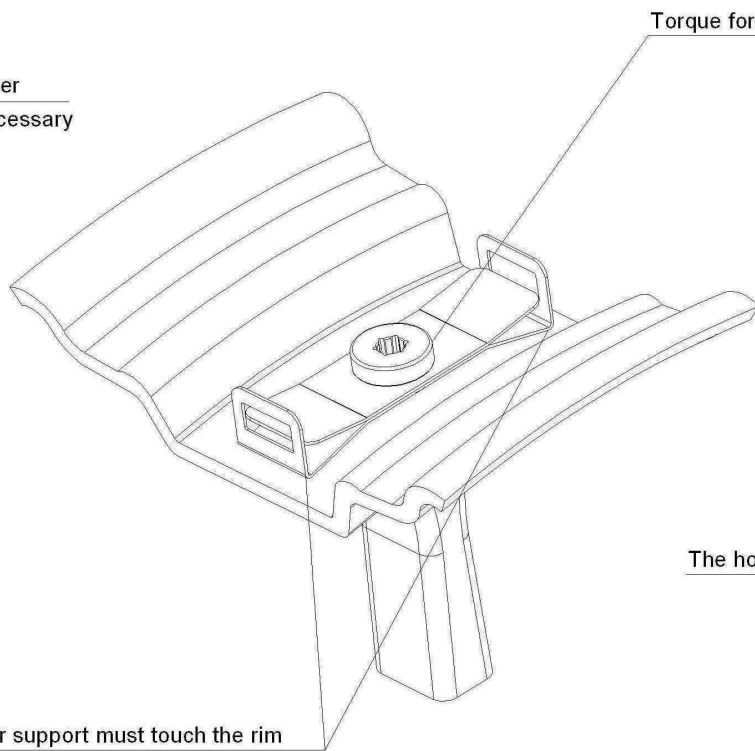

Torque force: 6 ± 1 Nm

The hole on rim must be threaded

